

Note: For information on Crusader oil coolers see page 21.

OIL COOLERS

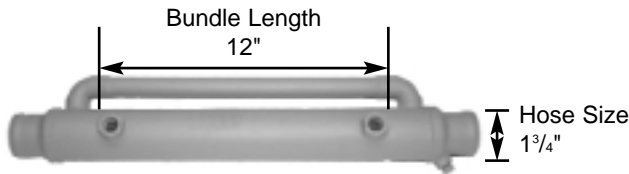

1234

Oil Cooler. For keel cooling

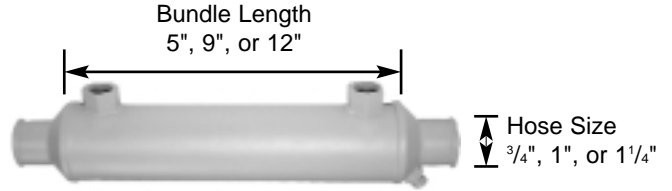

Oil Cooler

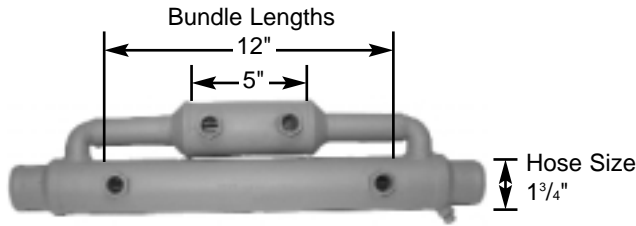

9398

Dual Oil Cooler. For keel cooling. Engine oil and transmission oil.

Part No.	Bundle Length	Hose ID
50C-075	5"	3/4"
50C-100	5"	1"
50C-125	5"	1 1/4"
90C-075	9"	3/4"
90C-100	9"	1"
90C-125	9"	1 1/4"
120C-075	12"	3/4"
120C-100	12"	1"
120C-125	12"	1 1/4"

ENGINE MOUNTS

These adjustable anti-vibration engine mounts are specifically designed to withstand temperature extremes and prolonged exposure to salt, atmosphere, oil and grease. Their design and construction gives a soft cushioning effect under normal loads. There is no metal to metal contact at any point over the weight range, eliminating any danger of excessive impact. These mounts have a one inch vertical adjustment using two hex jam nuts. The mounting holes are 4" on center and will accept 1/2" bolts.

Part No.	Length	Width	Height	Stud Thread
DF-206	5 3/16"	2 3/4"	4 9/16"	5/8-18
DF-216	5 3/16"	2 3/4"	4 9/16"	3/4-16

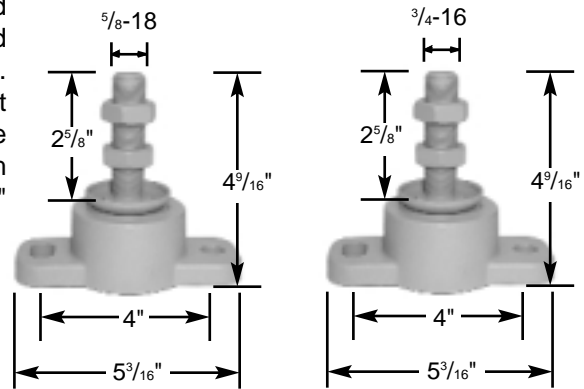

DF-206

DF-216

Note: These two mounts replace most of the mounts in use on in-line 4 / 6 cylinder and V6 and V8 gasoline engines produced since the early 70's. They are used on most I/O and Inboard gasoline engines from Mercruiser, OMC, Volvo, Marine Power, Indmar and Pleasurecraft and will also replace the Osco #'s DF-200 and DF-210 which measured 4 3/16" H x 5" L x 2 3/4" W x 2 1/2" stud.

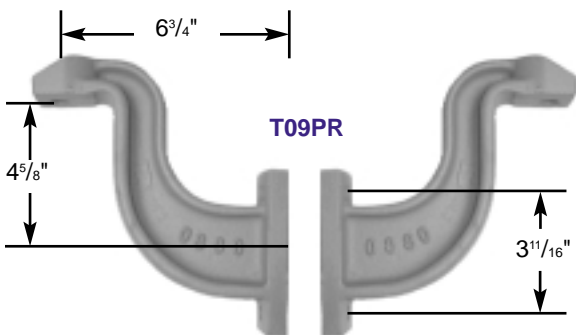

T09PR

TRANSMISSION MOUNTS

These mounts will fit all Warner Velvet Drive transmissions, as well as most Paragon transmissions.

T09PR Transmission Mount, Pair. Mounts 4 5/8" above centerline of transmission on 3 1/16" bolt centers.



Exhaust Elbows

Sold individually

Cast Iron



203030



453030



603030

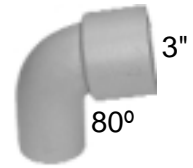

803023

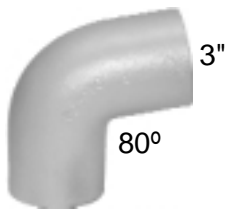

803030

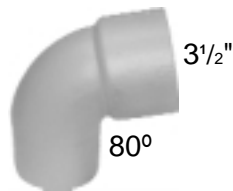

803035

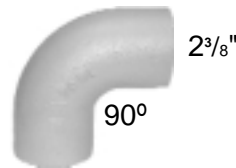

902323

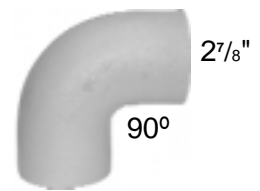

902828

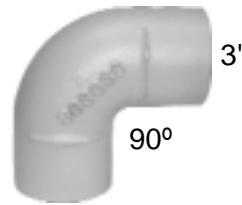

903030

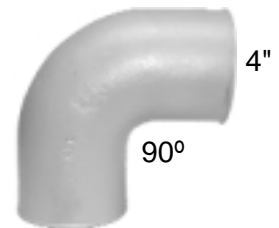

904040

58

Hose Adapters

Cast Iron



2330HA



3035HA



3040HAF
(Fiberglass)

NOTE: For elbow and hose adapter kits see page 41.

© Copyright 2001 Osco Motors Corp. All Rights Reserved. *Osco* is a registered trademark of Osco Motors Corp.



OSCO MOTORS CORP.
(800) 762-6726

2326 NORTH PENN ROAD
MANUFACTURER OF MARINE EXHAUST SYSTEMS SINCE 1932

HATFIELD, PA 19440
FAX (215) 822-5394

Sold individually

Exhaust Wyes

Cast Iron



2530Y



2535Y



2540Y



2830Y



2845Y



3030Y



3035Y



3040Y



3045Y



3050Y



4050Y

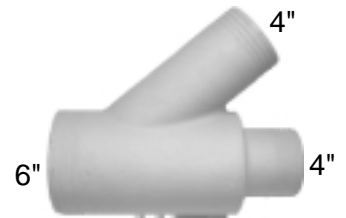

4060Y

Exhaust Tees

59

Cast Iron



3040T

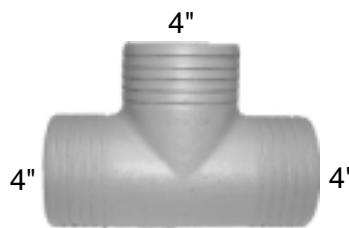

4040T



4050T

© Copyright 2001 Osco Motors Corp. All Rights Reserved. *Osco* is a registered trademark of Osco Motors Corp.



OSCO MOTORS CORP.
(800) 762-6726

2326 NORTH PENN ROAD
MANUFACTURER OF MARINE EXHAUST SYSTEMS SINCE 1932

HATFIELD, PA 19440
FAX (215) 822-5394

BELL HOUSINGS

Aluminum

Engines are listed by the car division that manufactures the engine. For example, the 231 CID V6 engine in an Oldsmobile is manufactured by, and listed under Buick.

Buick, Oldsmobile, Pontiac



BT

225, 231 cu.in. V6 Buick (1964-up)
300-455 cu.in. V8 Buick (1957-up)
260-455 cu.in. V8 Olds (1964-up)
260, 350 cu.in. Olds Diesel (1978-up)
301-455 cu.in. V8 Pontiac (1964-up)

Chevrolet Straight Six



CW

198-292 cu.in. 6 cyl Chevrolet (1962-up)
12" Flywheel

Chevrolet V6 and V8



CV

262-454 cu.in. V8 Chevrolet (1955-up)
14" Flywheel
Use with block mounted or bell housing mounted starter.

Chevrolet Diesel



CD

6.2/6.5 liter Chevrolet diesel (1982-up)

Ford V8



FH

429,460 cu.in. V8 Ford (1968-up)

Ford Diesel



DF

144-193 cu.in. Ford diesel (1953-up)

Ford Diesel



DE

220-380 cu.in. Ford Diesel (1955-up)

SAE Pattern #2



E2

SAE Pattern #3



E3

NOTE: The bell housings adapt Borg/Warner Velvet Drive and Paragon models P, G, and HF7 transmissions to the engines listed.



DRIVE DAMPERS

Transmission Drive Damper Plates for Flywheel End

<u>Part #</u>	<u>Center to Outside</u>	<u>Spline</u>	<u>Cubic Inch Displacement</u>
AS1K2C	6 ³ / ₁₆ "	26	UP TO 175 CID
AS4K2C*	6 ⁵ / ₈ "	26	251 to 360 CID

* Most commonly used on 318 - 360 Chrysler, 302 - 351 Ford and 283 - 350 Chevrolet engines, inboard applications.

TRIANGULAR FLYWHEEL END



<u>Part #</u>	<u>Outside</u>	<u>Spline</u>	<u>Cubic Inch Displacement</u>
AS7K2	13 ⁵ / ₁₆ "	10	331 to 459 CID
AS7K2C*	13 ³ / ₁₆ "	26	331 to 459 CID

* Most commonly used on 383 - 440 Chrysler, 396 - 454 Chevrolet, and 455 Oldsmobile engines, inboard applications.

FULL CIRCLE FLYWHEEL END



Transmission Drive Damper Plate for Timing Gear End (Flywheel Forward)

<u>Part #</u>	<u>Outside</u>	<u>Spline</u>	<u>Cubic Inch Displacement</u>
AS1K1C	6 ³ / ₁₆ "	26	UP TO 250 CID

SMALL CIRCLE TIMING GEAR END



INTAKE MANIFOLD

Aluminum

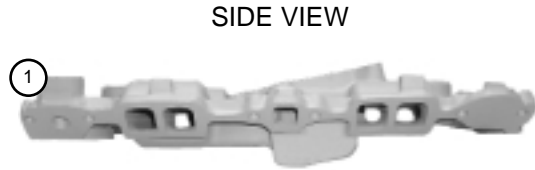

Flywheel Forward, Low Profile

TOP VIEW



1. **827-1621-CC** Aluminum intake manifold. Exact replacement for the low profile intake used on GM small block V8 flywheel forward engines marinized by Chris Craft.

INSTRUMENT PANELS

Durable, weather-resistant, marine instrument panels. Each panel includes tachometer for use with 4, 6, or 8 cylinder engines, voltmeter, oil pressure and water temperature gauges with single station senders, panel lights, and ignition switch with two keys. Each panel is fuse protected and plugs directly into OSCO's double ended wire harnesses, available in 10, 20, and 30 foot lengths, which also plug into the 3 foot engine harness.

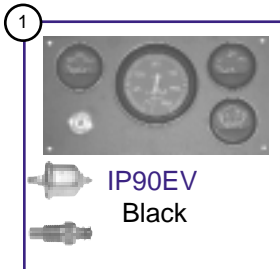

- | | | |
|----|-----------------|------------------------|
| 1. | IP90EV | Single Panel, Black |
| 2. | IP100EV | Dual Panel, Black |
| 3. | IP100EVW | Dual Panel, Wood Grain |
| 4. | WH-3 | Engine Harness, 3 Ft. |
| 5. | WH10 | Wire Harness, 10 Ft. |
| 6. | WH20 | Wire Harness, 20 Ft. |
| 7. | WH30 | Wire Harness, 30 Ft. |



PIPE PLUGS



1016002
1/8" MPT
Brass



1016004
1/4" MPT
Brass



1016006
3/8" MPT
Iron



1016008
1/2" MPT
Iron



1016012
3/4" MPT
Iron



1016016
1" MPT
Iron



3882
1 1/8"
Expansion Plug
Brass

FITTINGS



F46CS
Brass
1/2" MPT x 3/4"
Hose Barb



F66CS
Brass
3/4" MPT x 3/4"
Hose Barb



F68CS
Bronze
3/4" MPT x 1"
Hose Barb



F68C9
Bronze
3/4" MPT x 1"
Hose Barb



7854
Bronze
1" MPT x 1 1/4"
Hose Barb



F45NS
Nylon
1/2" MPT x 5/8"
Hose Barb



F45N9
Nylon
1/2" MPT x 5/8"
Hose Barb



F65NS
Nylon
3/4" MPT x 5/8"
Hose Barb



F65N9
Nylon
3/4" MPT x 5/8"
Hose Barb



F68N9
Nylon
3/4" MPT x 1"
Hose Barb

ZINC PENCILS



2209-ZP
For 2209 Series
oil coolers



1290-ZP
For 1290 Series
Heat Exchangers



VO-ZP
For Volvo
VO418 Manifold

